

**SONY**

3-754-020-22 (2)

# ***Stereo Cassette Deck***

---

Operating Instructions

*TC-C5*

# WARNING

To prevent fire or shock hazard, do not expose the unit to rain or moisture.

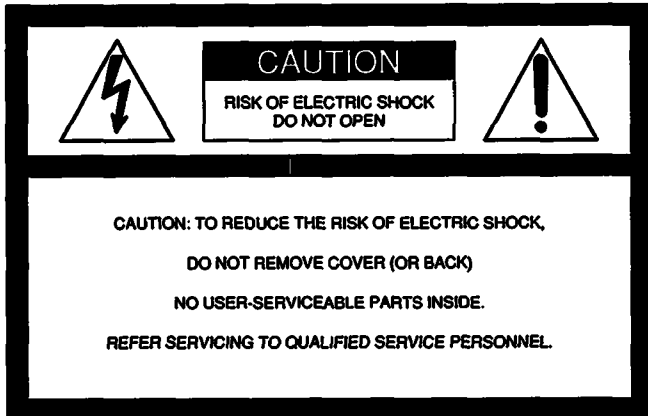

This symbol is intended to alert the user to the presence of uninsulated "dangerous voltage" within the product's enclosure that may be of sufficient magnitude to constitute a risk of electric shock to persons.



This symbol is intended to alert the user to the presence of important operating and maintenance (servicing) instructions in the literature accompanying the appliance.

\* The graphical symbols are on the rear enclosure.

## INFORMATION

This equipment generates and uses radio frequency energy and if not installed and used properly, that is, in strict accordance with the manufacturer's instructions, may cause interference to radio and television reception. It has been type tested and found to comply with the limits for a Class B computing device in accordance with the specifications in Subpart J of Part 15 of FCC Rules, which are designed to provide reasonable protection against such interference in a residential installation. However, there is no guarantee that interference will not occur in a particular installation. If this equipment does cause interference to radio or television reception, which can be determined by turning the equipment off and on, the user is encouraged to try to correct the interference by one or more of the following measures:

- Reorient the receiving antenna
- Relocate the equipment with respect to the receiver
- Move the equipment away from the receiver
- Plug the equipment into a different outlet so that equipment and receiver are on different branch circuits.

If necessary, the user should consult the dealer or an experienced radio/television technician for additional suggestions. The user may find the following booklet prepared by the Federal Communications Commission helpful:  
"How to Identify and Resolve Radio-TV Interference Problems". This booklet is available from the U.S. Government Printing Office, Washington, DC 20402, Stock No. 004-000-00345-4.

### INFORMATION (Canada only)

This apparatus complies with the Class B limits for radio noise emissions set out in Radio Interference Regulations.

### Owner's Record

The model and serial numbers are located at the rear.  
Record the serial number in the space provided below.  
Refer to these numbers whenever you call upon your Sony dealer regarding this product.

Model No. TC-C5    Serial No. \_\_\_\_\_

# Table of Contents

## Chapter 1 Introduction

# Features

## Chapter 1 Introduction

Features .....	3
Precautions .....	4

## Chapter 2 Getting Started

Unpacking .....	4
Checking the supplied accessories .....	4
Notes on installation .....	4
Removing the transportation screw .....	4
Checking the operating voltage .....	4
Hooking up the system .....	5
Before you begin .....	5
Hook-up example .....	5
Hook-up for tape dubbing .....	5
Identifying the parts .....	6
Front panel .....	6
Remote commander .....	7
Installing batteries into the remote commander .....	7

## Chapter 3 Changer Operation

Inserting cassettes .....	8
Playing back sequentially .....	9
Playing back .....	9
Rewinding all the cassettes — All Rewind .....	10
Skipping a blank — Blank Skip .....	10
Locating a selection — AMS .....	11
Shuffle Play .....	11
Program Play .....	12
Recording CDs sequentially — CD Synchro .....	13
Recording sources sequentially .....	14

## Chapter 4 Single Cassette Operation

Playing back .....	15
Starting playback after rewinding — Auto Play .....	16
Locating a desired playback position — Memory Play .....	17
Recording .....	18
Recording a source on a single cassette .....	18
Adjusting the recording level .....	19
Cassette care .....	19
What is the Dolby HX PRO system? .....	19
Inserting a blank — Record Muting .....	20
Timer-activated playback and recording .....	20

## Chapter 5 Additional Information

Maintenance .....	21
Cleaning the heads and tape path .....	21
Demagnetizing the heads .....	21
Cleaning the cabinet .....	21
Specifications .....	22
Troubleshooting guide .....	23

The TC-C5 is a five-cassette changer that allows the sequential playback and recording of multiple cassettes.

### For your convenience

- **Shuffle Play function** which provides random playback of up to 5 cassettes.
- **Program Play function** which allows you to freely specify the cassette playback sequence.
- **CD Synchro function** which allows you to record up to 5 CDs on 5 cassettes in synchronization with a Sony 5-disc CD changer.
- **Sequential Recording function** which allows you to record one of several sound sources on up to 5 cassettes in succession.
- **Quick reversing** at the end of a tape to minimize interruptions during playback and recording.
- **The AMS, Blank Skip and Memory Play functions** which provide easy access to a desired selection.
- **Timer-activated playback and recording** through the use of an optional timer.

### For higher quality recording/playback

- **The Dolby HX PRO\* system** which improves the linearity of the tape's high-range response during recording.
- **B and C type Dolby NR\* systems** which reduce tape noise.

\* Dolby noise reduction and HX Pro headroom extension manufactured under license from Dolby Laboratories Licensing Corporation. HX Pro originated by Bang & Olufsen.

"DOLBY", the double-D symbol  and "HX PRO" are trademarks of Dolby Laboratories Licensing Corporation.

**This unit is designed for home use.**

## Precautions

### On safety

- Should any solid object or liquid fall into the cabinet, unplug the unit and have it checked by qualified personnel before operating it any further.
- Unplug the unit from the wall outlet if it will not be used for a long time. To disconnect the cord, pull it out by grasping the plug. Never pull the cord itself.

### On operation

- When the unit is not used, turn the power off to conserve energy and to extend the useful life of your unit.
- Because of a safety mechanism, the function buttons will not operate if the cassette holder door is not completely closed, if there is no cassette in the cassette holder, or if a cassette has been incorrectly inserted into the cassette holder.

### On head cleaning

The head and tape path should be cleaned after every ten hours of operation. Dirty heads and a dirty tape path may cause:

- loss of high-frequency response
- loss of sound volume
- sound drop-out

If you have any questions or problems concerning your unit, please contact your nearest Sony dealer.

### Customer for the U.S.A.

For detailed safety precautions, see the leaflet "IMPORTANT SAFEGUARDS".

## Unpacking

### Checking the Supplied Accessories

Make sure that all supplied accessories are included with your unit. This manual and the following items are included with your TC-C5.

- Audio connecting cords (2)
- Wireless remote commander RM-J801 (1)
- Sony size-AA(R6) batteries (2)

### Notes on Installation

- Place the unit with the front panel facing you in a location with adequate air circulation to prevent overheating of the unit.
- Do not place the unit:
  - near heat sources such as radiators or air ducts.
  - in places subject to direct sunlight, excessive dust, mechanical vibration or shock.
  - in an inclined position.
  - on a rug or other soft surfaces that would block the ventilation holes on the bottom of the unit.

**Do not throw away the carton and the packing material** They will come in handy when transporting the unit or shipping it for servicing.

### Removing the Transportation Screw

A red transportation screw is attached to the rear of the unit to protect it against vibrations during transport. Be sure to remove the screw with a coin or a suitable screwdriver before plugging the power cord into a wall outlet. Store the transportation screw carefully since it will be needed when transporting the unit again.

### Checking the Operating Voltage

- Operate the unit only with a 120 V AC, 60Hz operating voltage.
- Before operating the unit, be sure that the operating voltage of your unit is identical with that of your local power supply.

# Hooking Up the System

## Before You Begin

- Turn off the power to all equipment to be connected before making any connection.
- Note that the red plug of the supplied connecting cord is for right-channel (R) connection and the white plug for left-channel (L) connection.
- The connecting cords should be fully inserted into the jacks. A loose connection may cause hum pickup.

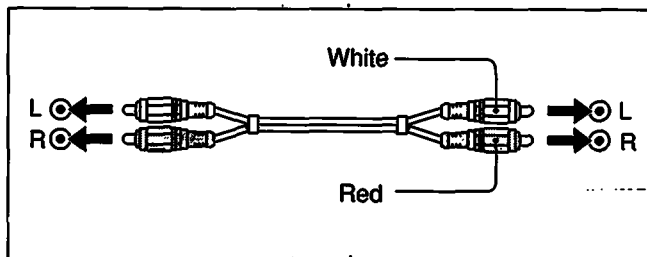

## Hook-up Example

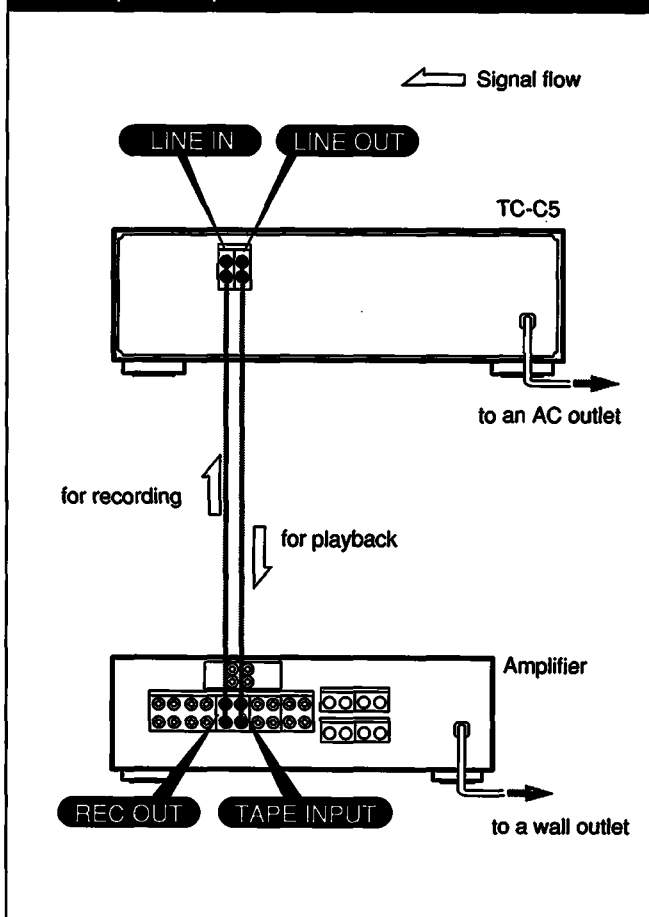

## Hook-up for Tape Dubbing

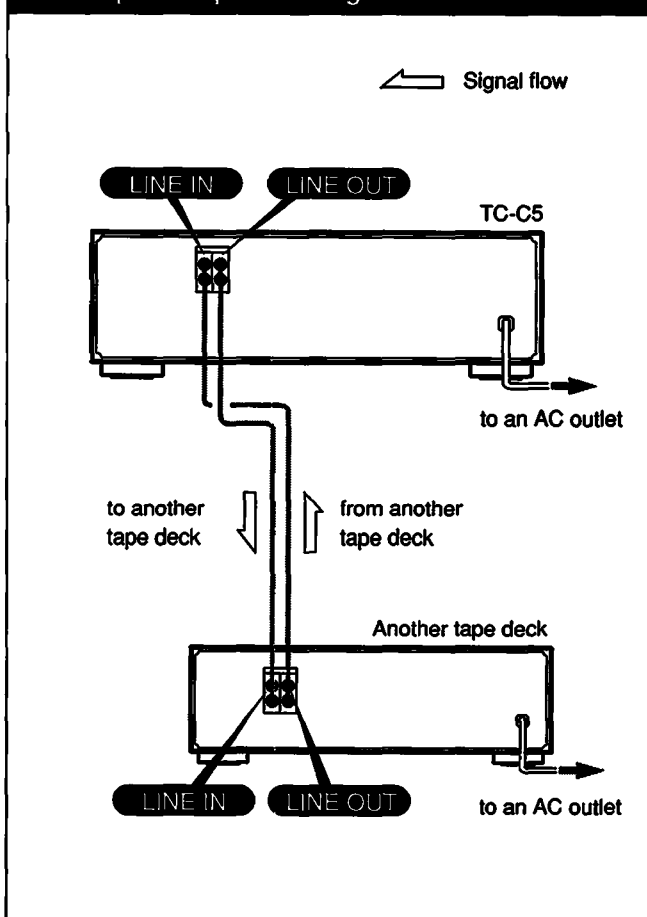

# Identifying the Parts

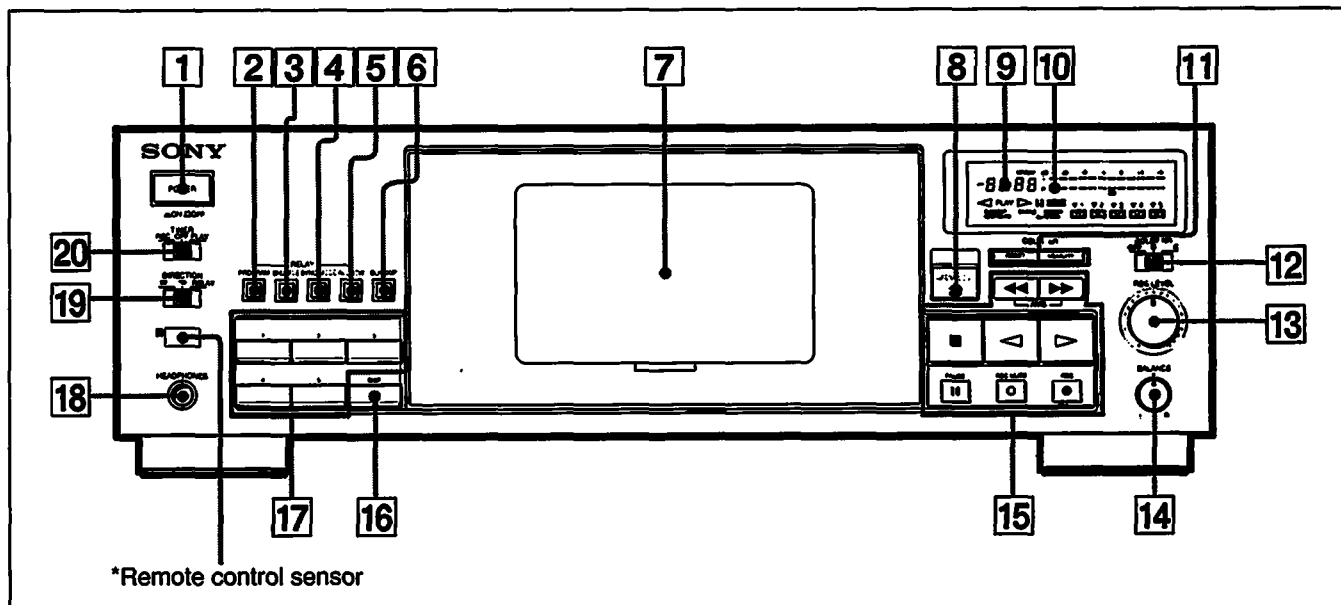

## Front Panel



For details, refer to the page number indicated in ●.

- 1 POWER switch
- 2 PROGRAM button 12
- 3 SHUFFLE button 11
- 4 SYNC MODE button 13
- 5 ALL REW (rewind) button 10
- 6 BLK (blank) SKIP button 10 13
- 7 Cassette holders
- 8 ▲ OPEN/CLOSE button
- 9 LINEAR COUNTER 17
- 10 PEAK LEVEL METER 16
- 11 COUNTER buttons  
RESET button 17  
MEMORY button 16 17
- 12 DOLBY NR (noise reduction) switch 9 14 15 16
- 13 REC (recording) LEVEL control 14 18 19
- 14 BALANCE control 14 18
- 15 Tape operation buttons  
◀◀ (leftward fast winding) button  
▶▶ (rightward fast winding) button  
■ (stop) button  
◀ (reverse play) button  
▶ (forward play) button  
|| PAUSE button  
○ REC MUTE (record muting) button 20  
● REC (record) button
- 16 SKIP button 8 14 15 16
- 17 Cassette buttons 9 12 14 15 16
- 18 HEADPHONES jack (stereo phone jack)
- 19 DIRECTION mode switch 9 14 15 16
- 20 TIMER switch 20

### \*Remote control sensor

- You can remotely control this cassette deck with:
- A remote commander that came with a Sony amplifier or receiver if it has the  mark and cassette deck control capability.
  - An optional Sony remote commander with the  mark and cassette deck control capability.

## Remote Commander

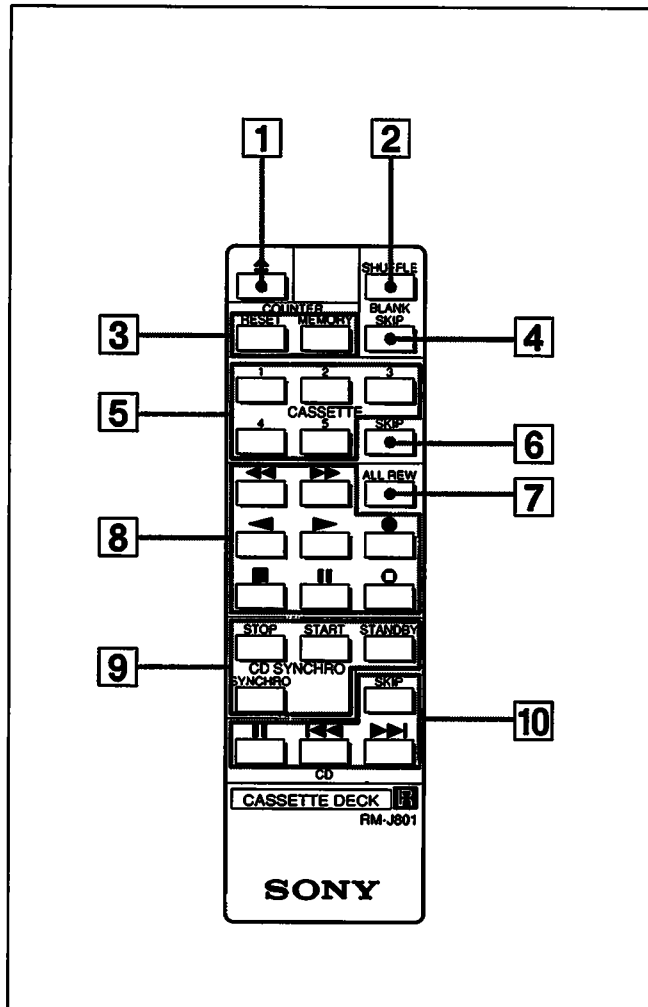

The controls on the remote commander are identical in function and operation to those with the same name on the main unit.

For details, refer to the page number indicated in ●.

- 1 ▲ (open/close) button
- 2 SHUFFLE button ●
- 3 COUNTER buttons ●
- 4 BLANK SKIP button ● ●
- 5 CASSETTE buttons ● ● ● ● ●
- 6 SKIP button ● ● ● ●
- 7 ALL REW (rewind) button ●
- 8 Tape operation buttons
- 9 CD SYNCHRO buttons ●  
for synchronized recording with a Sony CD player
- 10 CD (Compact Disc) buttons  
for controlling Sony CD players  
SKIP button  
|| (pause) button  
◀◀ / ▶▶ buttons for locating selections sequentially

## Installing Batteries into the Remote Commander

- 1 Open the cover.

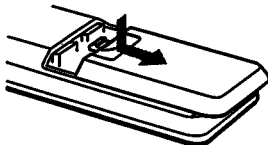

- 2 Insert two size -AA (R6) batteries.

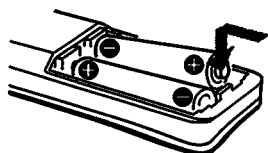

### On battery life

- About half a year of normal operation can be expected when using the Sony SUM-3(NS) batteries.
- When the batteries are run down, the remote commander will not operate the unit. In this case, replace both batteries with new ones.

### On handling

- Keep the commander away from extremely hot or humid places.
- Avoid dropping any foreign objects into the commander casing, particularly when replacing the batteries.
- Avoid exposing the remote sensor to direct sunlight or lighting apparatus. Such exposure can cause a malfunction.
- To avoid damage caused by battery leakage and corrosion, remove the batteries when the commander will not be used for a long time.

# Inserting Cassettes

Insert up to 5 cassettes into the appropriate holders before starting sequential playback or recording.

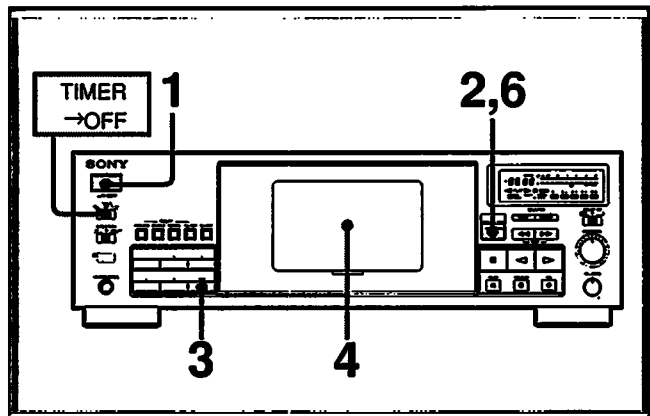

**1** Turn the power on.



**2** To open the cassette holder door, press OPEN/CLOSE.

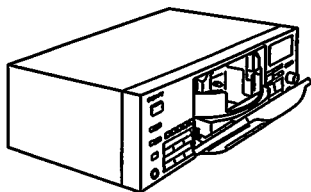

**3** To select a desired cassette holder, press SKIP.

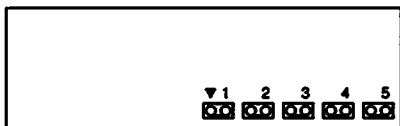
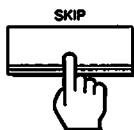

Each press of the SKIP button causes the changer to rotate to the next holder and a ▼ mark appears to the left of the currently selected cassette number. Each cassette holder is also identifiable by its cassette number which appears in relief on the cassette holder.

**4** With the desired cassette holder in front of you, insert the cassette to be first played into the cassette holder with the tape opening of the cassette facing downward.

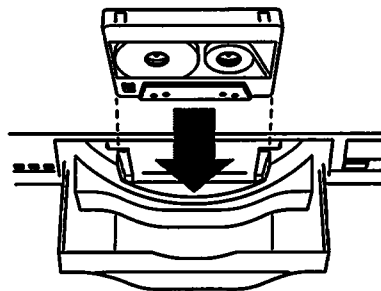

### Notes

- Do not attempt to insert a cassette while the changer is rotating. Make sure the changer has stopped before inserting the desired cassette.
- Never insert a cassette behind the holder and into the head area as this may cause damage to the cassette holder door.

**5** Repeat steps 3 through 4 until all the desired cassettes have been inserted.

**6** Press the OPEN/CLOSE button to close the cassette holder door.

### Replacing cassettes

Press the OPEN/CLOSE button to open the cassette holder door, then the SKIP button or the corresponding cassette button to rotate the changer to the desired holder. After the changer has stopped completely, replace the current cassette with the desired cassette.

### Identifying the currently selected cassette number

The ▼ mark appears to the left of the currently selected cassette number. The current cassette number can also be verified by the number that appears on the cassette holder.

### If the current cassette is improperly inserted

If the current cassette is inserted incorrectly, one attempt is made to load the cassette into the deck; the cassette holder door will then open automatically. The ▼ mark blinks during this time to indicate that the unit is still searching for the cassette. When this occurs, open the cassette holder and reinsert the cassette correctly.



# Playing Back Sequentially

## Playing Back

The Sequential Play function plays back in sequential order up to 5 cassettes inserted into the cassette holders. Sequential Play begins from the specified cassette number and automatically stops after playing the front and reverse sides of all remaining cassettes with larger cassette numbers.

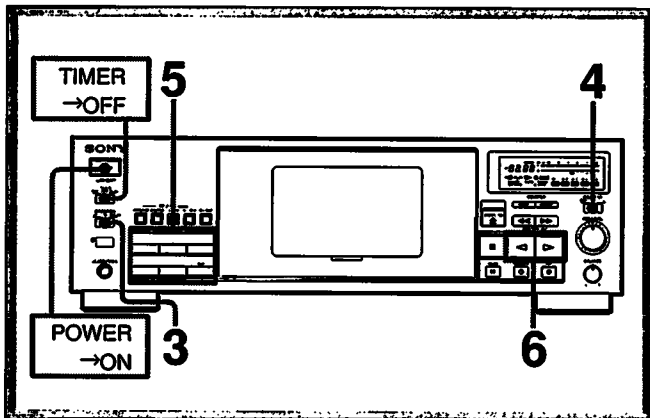

**1** Turn on the amplifier and select SOURCE.

**2** Perform steps 1 through 6 on page 8 to insert the desired cassettes.

**3** Set DIRECTION to RELAY.



**4** Set DOLBY NR to the same position that was used when the cassettes were recorded.

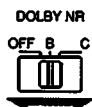

**5** Press the cassette button of the cassette with the smallest cassette number of the cassettes to be sequentially played.

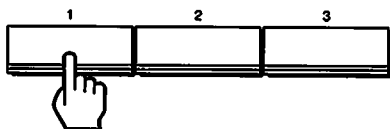

The cassette may also be selected by pressing the SKIP button, checking the current cassette number on the display panel.

**6** Press the PLAY button.

To playback from the front side, press  $\triangleright$ .

To playback from the reverse side, press  $\triangleleft$ .

To stop playback, press the  $\blacksquare$  button.

To stop playback momentarily, press the  $\parallel$  button.

To restart playback, press the  $\parallel$ ,  $\triangleleft$  or  $\triangleright$  button.

To fastwind a tape rightward, press the  $\triangleright\triangleright$  button in stop mode.

To fastwind a tape leftward, press the  $\triangleleft\triangleleft$  button in stop mode.

If the DIRECTION switch is not set to RELAY

The DIRECTION switch must be set to RELAY for Sequential Play. If not, playback stops after one or both sides of the current cassette finishes.

If you skip to another cassette while the current tape is in playback or pause mode

Pressing the SKIP button or a cassette button during playback of the current cassette causes the changer to move to the respective cassette and to start playing from the front side. Pressing the SKIP button or a cassette button while the current cassette is in pause mode causes the changer to move to the respective cassette and the unit to enter pause mode on the front side.

If a cassette is missing during the Sequential Play

The respective cassette number and cassette display turn off. If, for example cassette holder 3 is empty during sequential playing of cassette numbers 1 to 5, 3 is skipped and the cassettes in cassette holders 1, 2, 4 and 5 are played in sequence.

If a cassette holder is empty

When a cassette holder is empty, its cassette display and cassette number turn off.

The TIMER switch must be set to OFF

Otherwise, recording or playback will start automatically when the power is turned on.

What is the Dolby NR system?

The Dolby NR (noise reduction) system reduces tape hiss noise in low-level, high-frequency signals by boosting the signals during recording and lowering them during playback.

Note

The Dolby HX PRO system is effective only during recording, not during playback.

# Playing Back Sequentially

## Rewinding All the Cassettes — All Rewind

The All Rewind function automatically rewinds all the cassettes inserted into the cassette holders. The All Rewind function can be conveniently used prior to the start of Sequential Play.

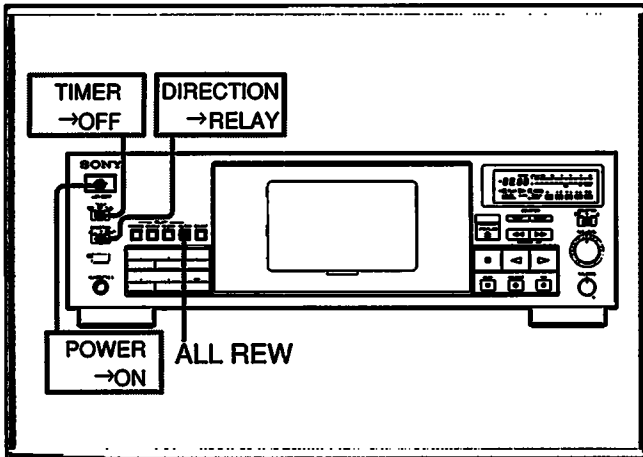

When all cassettes have been played and the unit has entered stop mode, press ALL REW.



The All Rewind function starts rewinding from the smallest cassette number and stops when all cassettes have been rewound. The changer then returns to the smallest cassette number and the unit enters stop mode.

To cancel the All Rewind function, press the **■** button or any other function buttons.

If you press a cassette button or the SKIP button during the All Rewind function, the function is cancelled and the unit changes to the respective cassette number and enters stop mode.

### Note

The Memory Stop function is disabled during the All Rewind function even if the Memory indicator is on.

## Skipping a Blank — Blank Skip

The Blank Skip function detects a blank of more than ten seconds, causes the unit to fast forward to the next recorded section, then starts playback again.

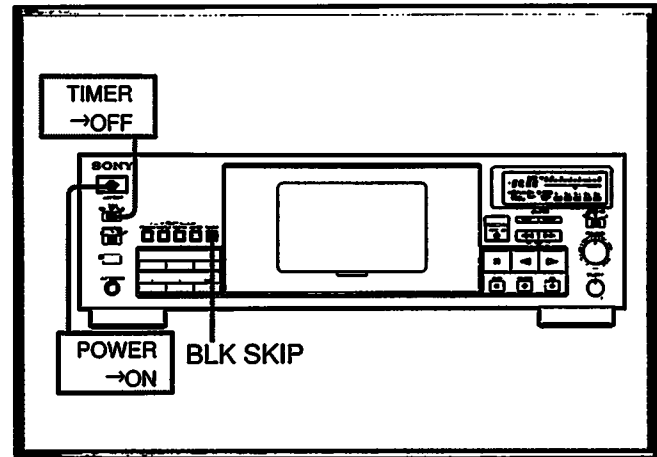

Activate the Blank Skip function by pressing BLK SKIP.



BLANK SKIP

### To deactivate the Blank Skip function

Press the BLANK SKIP button, turning off the BLANK SKIP indicator.

If the Blank Skip function does not operate properly  
There is an interval of little or no sound between tracks or within a selection.

If the PLAY indicator begins to blink during playback  
This indicates that the Blank Skip function is operating.

# Shuffle Play

## Locating a Selection — Automatic Music Sensor (AMS)

The AMS function detects the blank space between selections, allowing you to quickly locate the beginning of desired selections.

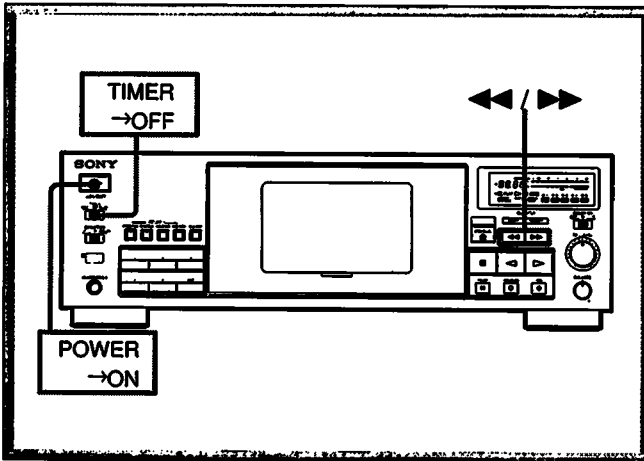

During playback, check which direction indicator is on and press **▶▶** or **◀◀**, referring to the following table.

Direction indicator	Press for	
	Next selection	Selection being played
PLAY ▶	▶▶	◀◀
◀PLAY	◀◀	▶▶

The PLAY indicator flashes while the AMS searches for the beginning of the selection. After locating the beginning of the selection, playback will start automatically.

**The AMS may skip a selection in the following cases:**

- If the **▶▶** (or **◀◀**) button is pressed immediately before the following selection.
- If there is noise in the space between selections.
- If the space is less than four seconds long.

**The AMS will treat the following as blanks:**

- a long pause in the music
- a passage of low frequencies or very low volume
- a gradual increase or decrease in volume

Shuffle Play plays back all loaded cassettes in random order.\*

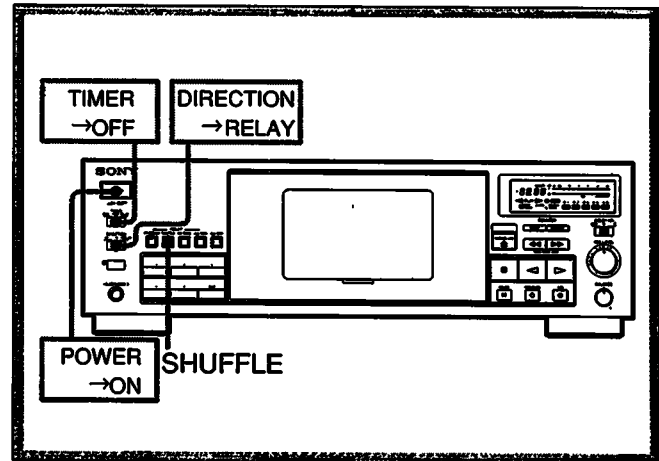

Press **SHUFFLE** while the unit is in stop mode. The SHUFFLE indicator appears and Shuffle Play begins.



\*Shuffle Play randomizes the playing order of cassettes, not selections.

**To cancel Shuffle Play, Press the ■ button.**

**To pause during Shuffle Play, Press the ||| button.**

**To start playback again, Press the |||, ▶ or ◀ button.**

The AMS function can also be used during Shuffle Play.

**To deactivate Shuffle Play and return to normal Play mode**

Press the SHUFFLE button to turn off the SHUFFLE indicator.

**If the program indicator is on**

Turn it off by pressing the program button.

**When a cassette finishes playing**

Its cassette display turns off and the next cassette is randomly selected and played.

**When Shuffle Play finishes playing all cassettes**

Shuffle Play is automatically cancelled, the unit changes to normal play mode and the cassette displays turn on.

**If you press the SKIP button during Shuffle Play**

Playing of the current cassette stops and the next cassette is randomly selected and played.

# Program Play

Program Play allows you to program the playback sequence of up to 5 cassettes.

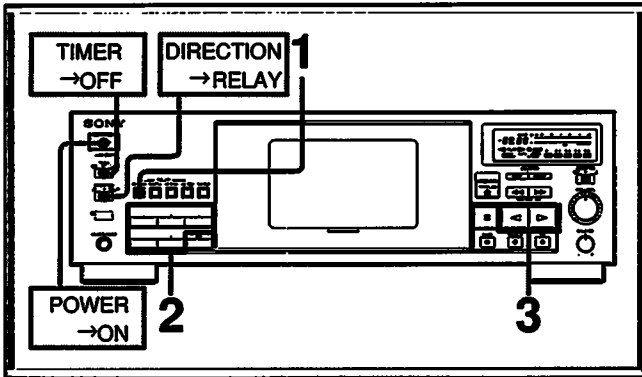

**1** Press PROGRAM while the unit is in stop mode.



The PROGRAM indicator appears and the cassette displays turn off. Only the cassette numbers remain on.

**2** Press the cassette buttons in the sequence the cassettes are to be played back, turning on the corresponding cassette display.

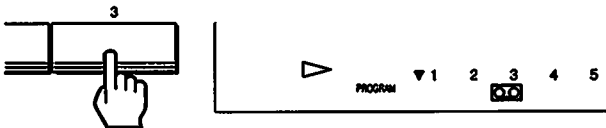

The numbers of lit cassette displays cannot be used again.

**3** After programming is completed, press the PLAY button.

To play back from the front side of the first cassette, press ►.

To play back from the reverse side of the first cassette, press ◀.

Each time a cassette finishes playing, its cassette display turns off.

To stop playback during Program Play, press the ■ button.

To pause during Program Play, press the || button.  
To resume playback, press the ||, ► or ◀ button.

To cancel Program Play, press the ■ button, then the PROGRAM button.

**After Program Play is finished**

The PROGRAM indicator turns off and the unit enters stop mode.

**To skip to the next cassette during Program Play**

Press the SKIP button during Program Play. The unit skips to the next programmed cassette number each time the SKIP button is pressed.

**Adding cassette numbers to the current program**

A cassette that has finished playing and whose cassette number has turned off can be added again to the present program. In this case, press the cassette button for the cassette number to be added. Cassette numbers can be added at any time until the Program Play function is cancelled.

# Recording CDs Sequentially — CD Synchro

The CD Synchro function allows you to sequentially record up to 5 compact discs on 5 cassettes through synchronized recording with an optional Sony multi-disc CD player. Before starting this procedure, make sure the PROGRAM or SHUFFLE indicator is off.

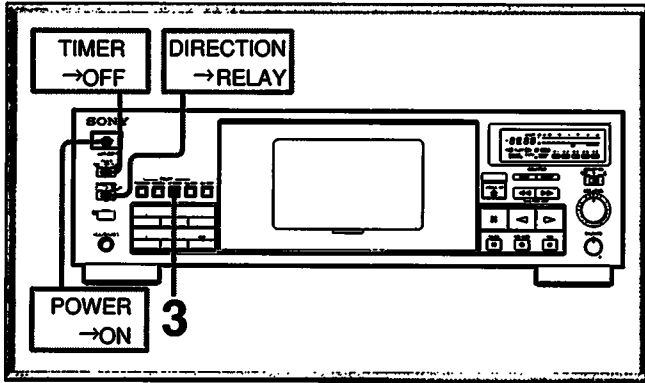

**1** Load the desired CDs into the CD player, then set the CD player to the continue 1 DISC mode and the amplifier source to CD. Insert the appropriate number of cassettes into the cassette holders of the TC-C5.

**2** Set the CD player to DISC 1 and select cassette number 1 on the TC-C5.

**3** Press the SYNC MODE button on the TC-C5.



The CD SYNCHRO indicator lights up.

**4** Press STANDBY on the remote commander.

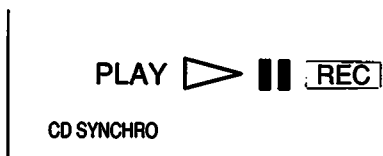
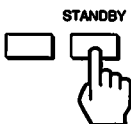

The CD player changes to standby in playback mode, and the TC-C5 changes to standby in recording mode on the front side of the 1st cassette.

**5** Press START on the remote commander to begin recording.

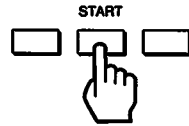

Standby is cancelled on the TC-C5 and CD player, and synchronized recording begins.

**6** When the first CD finishes playing, the DISC ENDS indicator appears on the CD player.

When recording of the 1st cassette ends, the TC-C5 records an 8-second blank on the front side of the 2nd cassette, enters recording pause mode and starts flashing the CD SYNCHRO indicator.

**7** Press SYNCHRO on the remote commander to start synchronized recording of the 2nd CD on the 2nd cassette.



By pressing the SYNCHRO button on the remote commander each time the TC-C5 changes to recording standby, each CD is recorded in sequential order.

## Before starting recording

Select the Dolby NR and adjust the recording level. (See pages 18 and 19.)

## After synchronized recording is completed

Press the SYNC MODE button on the TC-C5 while it is in stop mode to cancel the CD Synchro function.

## To cancel the CD synchro function

Press the ■ button to change the TC-C5 to stop mode, then press the SYNC MODE button.

## If synchronized recording is performed with the BLK SKIP button on

After the last track of a CD is recorded, a silent interval of more than 10 seconds activates the Blank Skip function, causing the CD Synchro function to move immediately to the next cassette.

The same thing occurs when an interval of little or no sound is detected between tracks or within a selection.

# Recording Sources Sequentially

Follow this procedure to sequentially record a source on up to five cassettes.

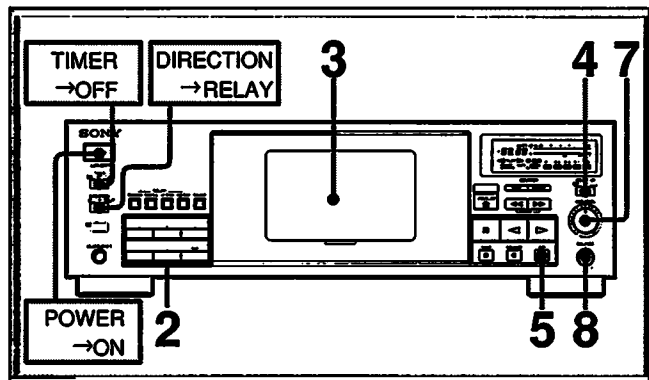

**1** Turn on the amplifier and select the tape function.

**2** Open the cassette holder door and select the desired cassette holder by pressing SKIP or the corresponding cassette button.

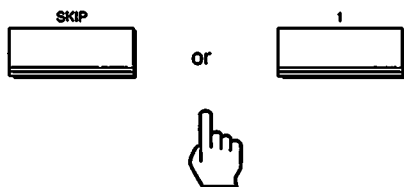

**3** Insert a cassette into the cassette holder.

See *Inserting Cassettes* on page 8.

**4** Select the Dolby NR setting.

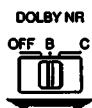

**5** Press ● REC to change the unit to recording pause mode.



## Note

A blinking direction indicator (◀ or ▶) indicates that recording is possible on that side.

If the cassette tab has been removed to prevent accidental erasure, the indicator will blink only for the side that can be recorded. If both tabs have been removed, there will be no response even when ● is pressed.

**6** Play the program source to be recorded.

**7** Adjust the recording level.

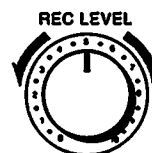

See *Adjusting the Recording Level* on page 19.

**8** Adjust the balance.



**9** Restart the program source, if required.

**10** Start recording.

To record on the front side of the cassette	
When ▶ is on	Press ▶ once or   .
When ◀ is on	Press ▶ twice.

To record on the reverse side of the cassette	
When ◀ is on	Press ◀ once or   .
When ▶ is on	Press ◀ twice.

**To stop recording**  
Press the ■ button.

# Playing Back

## Playing Back

Follow this procedure to play back a single cassette.

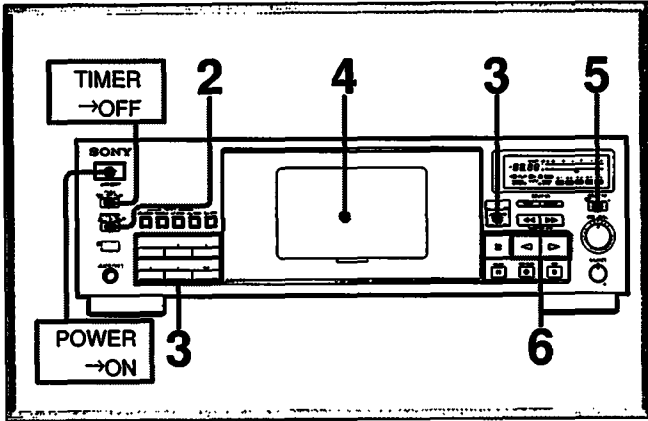

**1** Turn on the amplifier and select the tape function.

**2** Select the direction mode.

To playback one side	
To playback both sides	

**3** Open the cassette holder door and select the desired cassette holder by pressing SKIP or the corresponding cassette button.

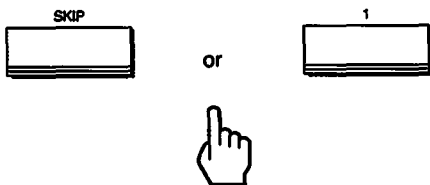

**4** Insert a cassette into the cassette holder.

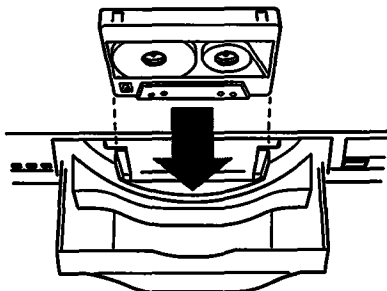

**5** Set DOLBY NR to the same position that was used when the cassette was recorded.

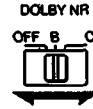

**6** Press the PLAY button.

To playback from the front side, press  $\triangleright$ .

To playback from the reverse side, press  $\triangleleft$ .

To stop playback, press the  $\blacksquare$  button.

To stop playback momentarily, press the  $\blacksquare$  button.

To restart playback, press the  $\blacksquare$ ,  $\triangleleft$  or  $\triangleright$  button.

To fastwind a tape rightward, press the  $\blacktriangleright\blacktriangleright$  button in stop mode.

To fastwind a tape leftward, press the  $\blacktriangleleft\blacktriangleleft$  button in stop mode.

To start operations while the cassette holder door is open

Operations may be started while the cassette holder door is open. For example, when the  $\triangleleft$  or  $\triangleright$  button is pressed while the cassette holder door is open, it will close and playback will start. Similarly, pressing the  $\blacktriangleleft$ ,  $\blacktriangleright$ , or  $\blacksquare$  buttons while the cassette holder door is open will close the cassette holder door and start the respective operation.

## Playing Back

### Skipping a Blank — Blank Skip

The Blank Skip function detects a blank of more than ten seconds, causes the unit to fast forward to the next recorded section, then starts playback again. Refer to **Skipping a Blank** on page 10.

### Locating a Selection — Automatic Music Sensor (AMS)

The AMS function detects the blank space between selections, allowing you to quickly locate the beginning of desired selections. Refer to **Locating a Selection** on page 11.

## Starting Playback After Rewinding — Auto Play

The Auto Play function automatically starts playing back a cassette after fast winding it to the beginning.

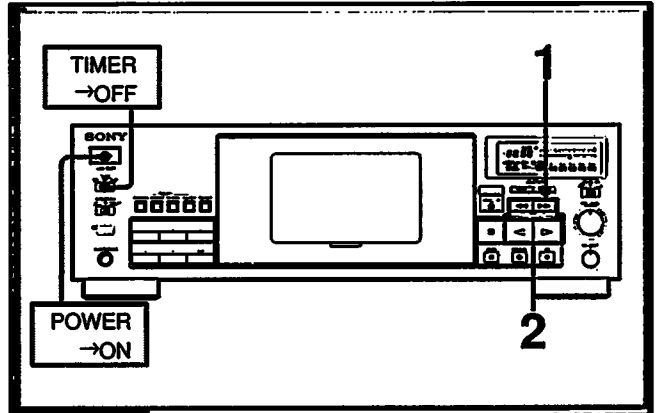

**1** Make sure the MEMORY indicator is off.

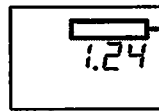

If the indicator is on, press MEMORY.

**2** While pressing ► or ◀, press ◀◀ or ▶▶.

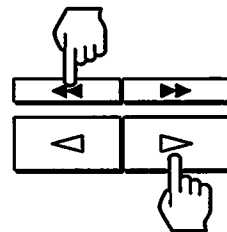

From the beginning of...	While pressing...
front side	►, press ◀◀.
reverse side	◀, press ▶▶.



# Locating a Desired Playback Position — Memory Play

The Memory Play function allows you to use the counter to record a desired position on a cassette for fast relocation and automatic playback later.

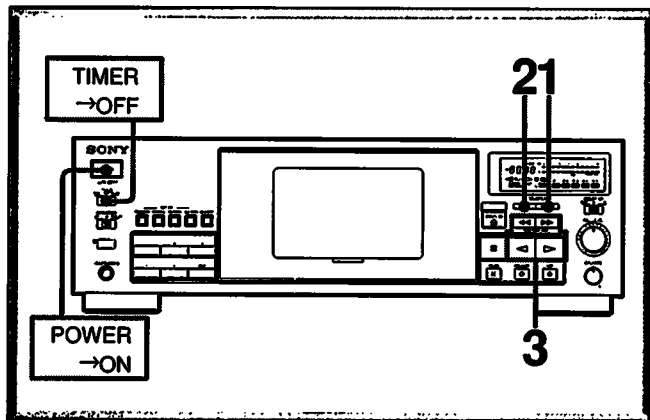

**1** Activate the Memory Play function.

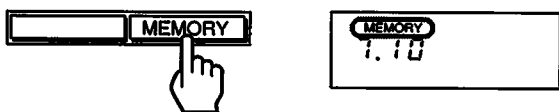

**2** At the desired position, reset the counter.

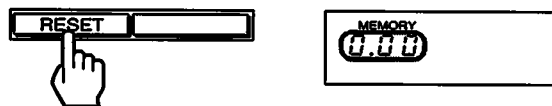

The desired position is memorized.

**3** To return to the desired position

Check the direction indicator and press the respective buttons shown below.

Direction indicator	While pressing...
PLAY ▷	▶, press ◀◀.
◁ PLAY	◀, press ▶▶.

**Returning to the memorized position in stop mode — Memory Stop**

If you press only the ◀◀ or ▶▶ button when the MEMORY indicator is on in the stop mode, the tape rewinds and the unit stops when the counter reaches 0.00.

Be sure to first stop playback before activating the Memory Stop function, otherwise the AMS function will activate.

**To deactivate the Memory Play function**

Press the MEMORY button, turning off the MEMORY indicator.

## The Accuracy of the Linear Counter

Since the counter is not a digital clock, the number will differ from the actual elapsed playback or recording time by a few minutes, depending on such factors as tape length and hub size.

**Note on Memory Play/Stop**

In actuality, the tape is rewound to slightly short of 0.00.

**Do not turn off the power while using the counter**

Turning the power off, then on again resets the counter to 0.00.

# Recording

## Recording a Source on a Single Cassette

Follow this procedure to record a source on a cassette.

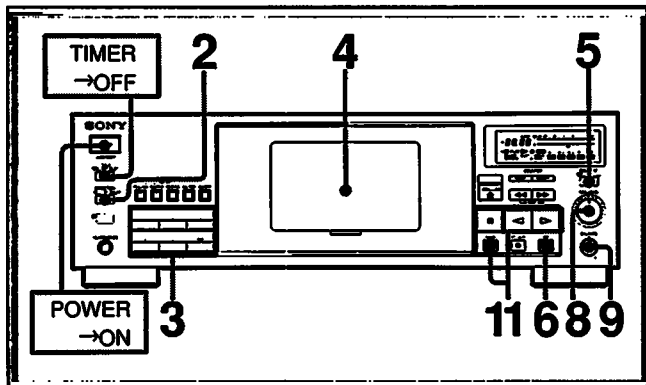

**1** Turn on the amplifier and select the tape function.

**2** Select the side(s) to be recorded.

To record on one side	
To record on both sides	

**3** Open the cassette holder door and select the desired cassette holder by pressing SKIP or the corresponding cassette button.

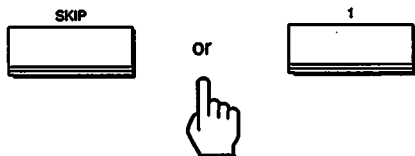

**4** Insert a cassette into the cassette holder.  
See **Inserting Cassettes** on page 8.

**5** Select the Dolby NR setting.

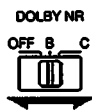

**6** Press ● REC to change the unit to recording pause mode.



### Note

A blinking direction indicator (◀ or ▶) indicates that recording is possible on that side.

If the cassette tab has been removed to prevent accidental erasure, the indicator will blink only for the side that can be recorded. If both tabs have been removed, there will be no response even when ● is pressed.

**7** Play the program source to be recorded.

**8** Adjust the recording level.

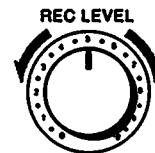

See **Adjusting the Recording Level** on page 19.

**9** Adjust the balance.



**10** Restart the program source, if required.

**11** Start recording.

To record on the front side of the cassette	
When ▶ is on	Press ▶ once or II.
When ◀ is on	Press ▶ twice.
To record on the reverse side of the cassette	
When ◀ is on	Press ◀ once or II.
When ▶ is on	Press ◀ twice.

**To stop recording**  
Press the ■ button.

**The TIMER switch must be set to OFF**  
Otherwise, recording or playback will start automatically when the power is turned on.

**To start recording while the cassette holder door is open**  
If you press the ● button while the cassette holder door is open, it will close automatically and the unit will switch to recording pause mode. This function allows you to start recording at a moment's notice.

**To change to recording mode during playback**  
Keeping the ◀ or ▶ button pressed, press the ● button. The unit immediately switches from playback to recording without stopping the tape. This is useful when editing previously recorded material.

### Checking the recording time on a tape

To check the remaining recording time on a tape:

- 1 Press the RESET button to reset the counter to 0.00.
- 2 Press ◀◀ or ▶▶ to advance the tape to its end. The number on the counter shows the approximate recording time.

To check the total recording time of a tape, first rewind the tape to its beginning, then follow the same steps as above.

## Adjusting the Recording Level

The optimum recording level, which differs according to the tape type, is indicated on the PEAK LEVEL METER for each tape type.

Adjust the REC LEVEL control as high as possible without exceeding the recommended range for the tape type being used.

### Recommended maximum PEAK LEVEL METER reading

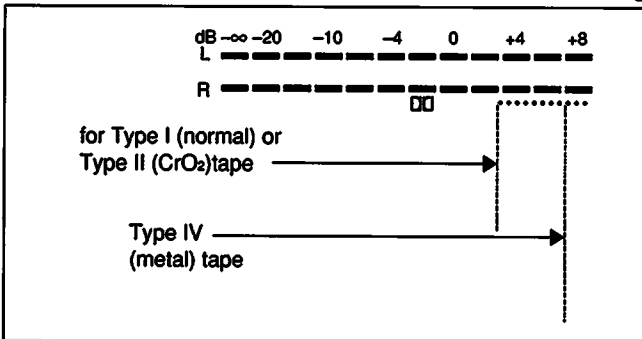

### Tips on recording level adjustment

- If the recording level setting is too high, the recording will be distorted; if it is too low, the tape will produce a hissing sound. Therefore, the recording level should be set as high as possible without causing distortion.
- If the program source to be recorded has many high frequency signals, set the level to a relatively low position.

## Cassette Care

**To protect a recording on side A or B**  
Break out the respective tab.

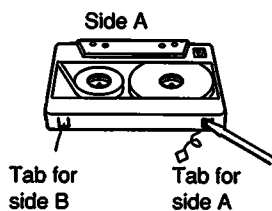

**To recover a cassette for recording**  
Cover the respective slot with tape.



**When using Type II (CrO<sub>2</sub>) or Type IV (metal) cassettes**  
Be careful not to cover the detector slots which are necessary for automatic tape detection.

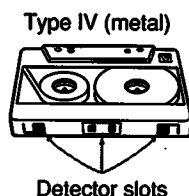
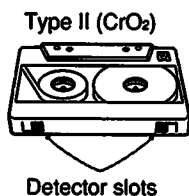

### Cassette care

- Avoid touching the tape surface of a cassette to prevent contamination of the heads by dirt, dust, or oil on the skin.
- Keep cassettes away from equipment with magnets, such as speakers and amplifiers, as erasure or distortion on the recorded tape could occur.
- Do not expose cassettes to direct sunlight, extremely cold temperatures or moisture.

### Note on cassettes longer than 90 minutes

The use of cassettes longer than 90 minutes is not recommended except for long continuous playback.

## What is the Dolby HX PRO System?

The Dolby HX PRO system provides improved linearity in high-range frequency response during recording. Tapes recorded with this system retain the same high quality even when played back on other tape decks.

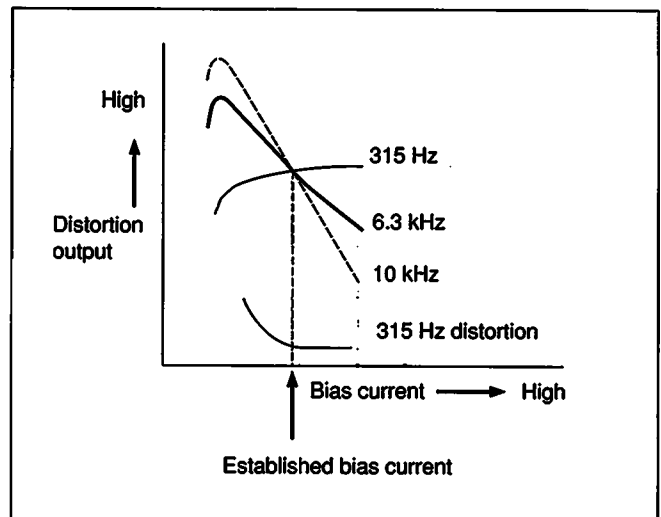

As shown above, characteristics such as output level and distortion differ widely according to the bias (high-frequency) current. In conventional systems, the bias current is susceptible to variations in certain recording signals (see diagram below) which may cause fluctuations in frequency response, distortion, or other unwanted characteristics.

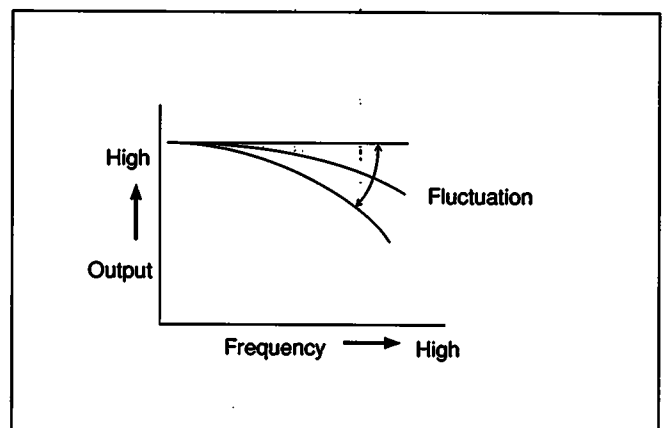

With the Dolby HX PRO system, the effective bias amount added to the bias current is controlled in millisecond units to greatly reduce distortion, improving linearity in high-range response and ensuring high-intensity recording with minimal distortion and noise.

# Inserting a Blank

## Record Muting

The Record Muting function allows you to insert a four-second blank to enable proper AMS operation (see page 11), and to replace unwanted input with a blank of any desired length.

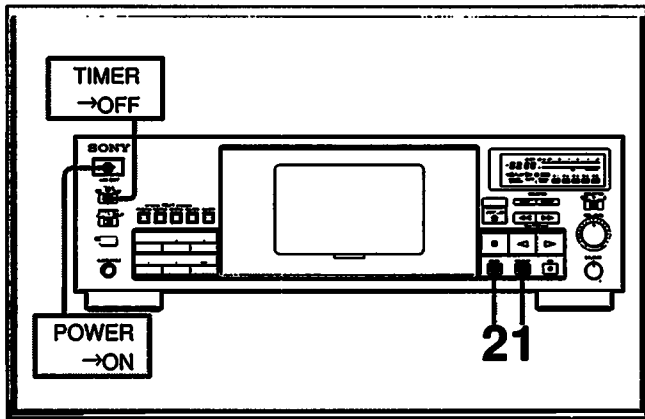

**1** While recording, press  and release it immediately.

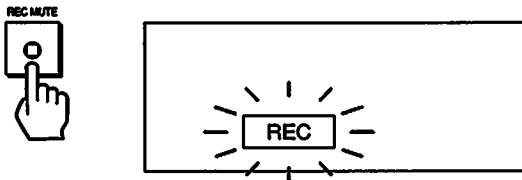



The **REC** indicator starts to blink. During this time, no incoming signals are recorded on the tape.

After four seconds, the  indicator lights up and the unit enters recording pause mode.

**2** Resume recording.



**To create a blank longer than four seconds**

While recording, press the  button for the desired length of time. After four seconds, the **REC** indicator blinks with greater rapidity. When you release the  button, the  indicator lights up and the unit goes into recording pause mode.

Press the  button to resume recording.

# Timer-Activated Playback and Recording

By connecting an optional timer, recording or playback can be performed automatically at a preset time.

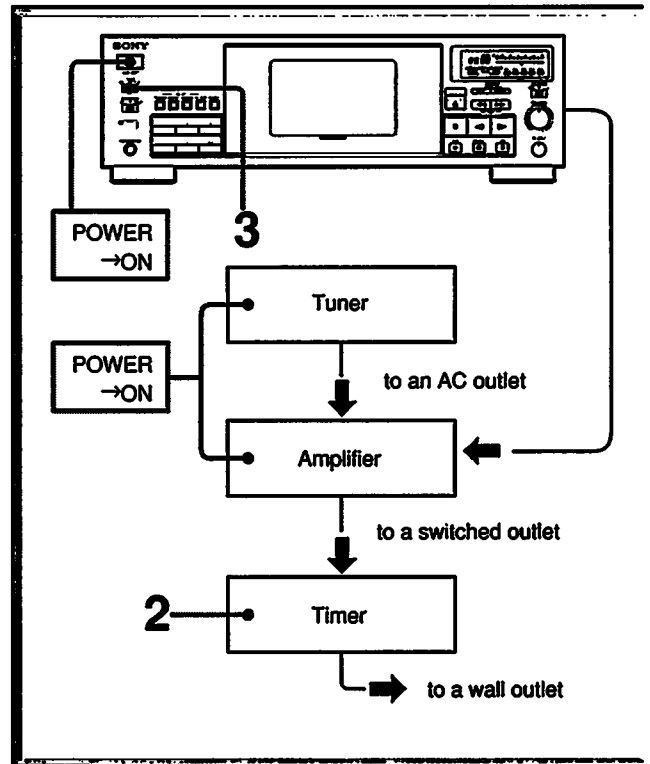

**1** Prepare the unit for playback or recording.

For sequential play	Follow steps 1 to 5 on page 9.
For single-cassette play	Follow steps 1 to 5 on page 15.
For sequential recording	Follow steps 1 to 8 on page 14.
For single-cassette recording	Follow steps 1 to 9 on page 18.

After completing the preparations, press the  button to change the unit to stop mode.

Make sure to close the holder door completely.

**2** Set the timer to the desired time.  
Power to the tape deck will be cut off.

**3** Set the deck's **TIMER** switch to **PLAY** or **REC**.  
Playback or recording will start at the preset time.

**Keep the POWER switch on the unit on**  
When the timer is set, the power to the unit will be cut off. However, the **POWER** switch must be on to start timer-activated operation.

**When the timer-activated operation is completed**  
Set the **TIMER** switch on the unit to **OFF**. If the **TIMER** switch is left at **REC**, the unit will automatically start recording the next time the power is turned on, and the previously recorded material may be erased.

# Maintenance

## Cleaning the Heads and Tape Path

Clean all surfaces over which the tape travels after every ten hours of operation to guard against:

- low-quality sound
- a decrease in sound level
- excessive wow, flutter or drop-out
- incomplete erasure
- impairment of recording function

To obtain high-quality recorded sound, cleaning before every recording is recommended.

- 1** Keeping the power on, turn the volume control on the amplifier to minimum.
- 2** Press  $\blacktriangle$  to open the cassette holder.
- 3** Wipe the heads, the pinch rollers and the capstans with a cotton swab slightly moistened with alcohol or commercially available cleaning fluid for tape decks.\*

Be careful not to press against the holder or holder door as this will cause the holder door to close.

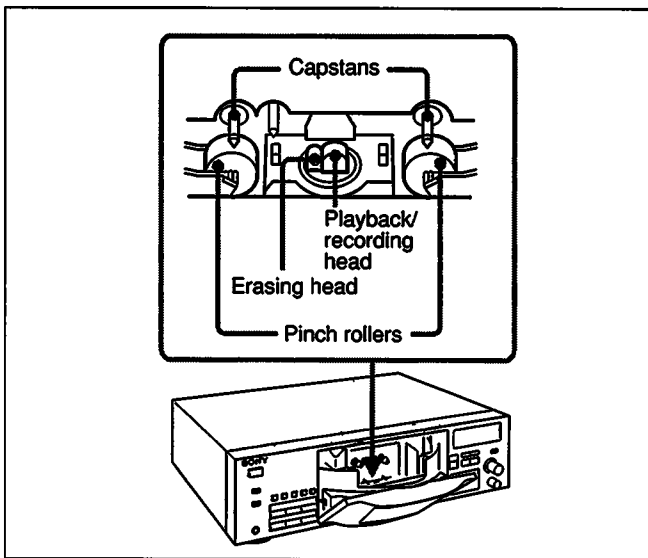

Do not insert a cassette until the cleaned areas are completely dry.

\*If the cottonswab is too short to reach the heads, use a commercially available head-cleaning cassette to clean the heads.

## Demagnetizing the Heads

After 20 to 30 hours of use, or when you notice hiss and/or loss of high frequencies, the residual magnetism built up on the heads should be removed.

- 1** Keeping the power on, turn the volume control on the amplifier to minimum.
- 2** Press  $\blacktriangle$  to open the cassette holder.
- 3** Demagnetize the heads with any commercially available demagnetizer.

Refer to the instruction manual of the demagnetizer for detailed instructions.

## Cleaning the Cabinet

Clean the cabinet, panel and controls with a soft cloth slightly moistened with a mild detergent solution. Do not use any type of abrasive pad, scouring powder or solvents such as alcohol or benzine.

# Specifications

Recording system 4-track 2-channel stereo  
 Fast-winding time Approx. 90 sec. (with Sony C-60 cassette)  
 Bias AC bias  
 Heads Erasing head × 1 (ferrite head)  
 Playback/Recording head × 1 (LA head)  
 Motors Capstan motor × 1 (DC servo motor)  
 Reel motor × 1 (DC motor)  
 ASIST (mechanical drive) motor × 3 (DC motor)

Signal-to-noise ratio (at peak level)

Cassette	Dolby NR switch		
	OFF	B-Type ON	C-Type ON
Type IV (Sony METAL-SLT)	59 dB	67 dB	74 dB
Type II (Sony UX-S)	58 dB	66 dB	73 dB
Type I (Sony HF-S)	56 dB	64 dB	71 dB

Total harmonic distortion

1% (with Sony METAL-SLT cassette)

Frequency response (DOLBY NR OFF)

Type IV cassette (Sony METAL-SLT)	20 - 19,000 Hz (±3 dB, IEC) 30 - 15,000 Hz [±3 dB 0VU (-4 dB recording)]
Type II cassette (Sony UX-S)	25 - 17,000 Hz (±3 dB, IEC)
Type I cassette (Sony HF-S)	25 - 16,000 Hz (±3 dB, IEC)

Wow and flutter ±0.09% W. Peak (IEC)  
 0.06% WRMS (NAB)  
 ±0.16% W. Peak (DIN)

Line inputs (phono jacks)

Sensitivity 77.5 mV  
 Input impedance 47 k ohms

Outputs

Line outputs (phono jacks)	Rated output level	0.32 V at a load impedance of 47 k ohms
	Load impedance	Over 10 k ohms
Headphones (stereo phone jack)	Output level	0.3 mW at a load impedance of 32 ohms

General

Power requirements 120 V AC, 60 Hz  
 Power consumption 20 W  
 Dimensions Approx. 430 × 135 × 350 mm (w/h/d)  
 (17 × 5<sup>3</sup>/<sub>8</sub> × 13<sup>7</sup>/<sub>8</sub> inches)  
 including projecting parts and controls  
 Weight Approx. 6.9 kg (15 lb 3 oz)

Supplied accessories

Audio connecting cords (2)  
 Wireless remote commander RM-J801(1)  
 Sony size-AA (R6) batteries(2)

Design and specifications are subject to change without notice.

# Troubleshooting Guide

The following trouble checks will help you correct the most common problems encountered with your tape deck. Should any problems persist after you have made these checks, consult your nearest Sony dealer.

Before proceeding with these trouble checks, verify that:

- The power cord is firmly connected.
- Amplifier connections are firmly made.
- Heads, capstans and pinch rollers are clean.
- The amplifier controls and switches are set correctly.

Function buttons and tape transport problems		
Symptom	Cause	Remedy
The function buttons do not activate.	The cassette is not properly inserted.	Insert cassette correctly.
	Button was pressed immediately after the power was turned on.	Wait until the ■■ indicator stops blinking.
Playback or recording begins when the power is turned on.	The TIMER switch is not set to OFF.	Set the TIMER switch to OFF.
The ● button does not activate.	There is no cassette in the holder.	Insert a cassette.
	A tab has been removed from the cassette.	Cover the slot with tape (page 19).
Automatic shut-off mechanism activates before the tape comes to its end.	The tape is slack.	Take up the tape slack.
	The cassette shell is deformed.	Use another cassette.
	The Memory Play function is activated.	Press the MEMORY button to deactivate the function.
Excessively loud tape transport noise during fast winding.	This noise is caused by the cassette and does not signify a mechanical problem.	—
The cassette holder will not close.	There has been a power failure or the power cord has been disconnected while the cassette holder is open.	Reconnect the power.
The ▲ button does not function.	There has been a power failure or the power cord has been disconnected.	Reconnect the power.
The changer does not turn properly.	An excessively heavy cassette has been inserted.	—
The ■■ indicator continues blinking.	The transportation screw on the rear panel is still attached.	Unplug the unit and remove the transportation screw.
The changer operates when the power is turned on.	This is not a malfunction. The unit is merely confirming the changer position.	—
The cassette holder door opens by itself when a cassette is loaded.	The cassette is incorrectly loaded.	Insert the cassette correctly.
	The cassette is deformed.	Substitute the tape with a normal one.
	An excessively heavy cassette has been inserted.	Use a regular cassette.

(Continued on next page.)

# Troubleshooting Guide

(Continued from previous page.)

Recording and playback problems		
Symptom	Cause	Remedy
Recording or playback cannot be made or there is a decrease in sound level.	The heads are either dirty or magnetized.	Clean or demagnetize the heads.
	Improper hook-up.	Make connections properly (page 5).
	Improper setting of the amplifier controls.	Set the amplifier controls to the appropriate positions.
Excessive wow, flutter or drop-out.	The head, capstan or pinch roller is dirty.	Clean in accordance with instructions (page 21).
Incomplete erasure.	The erasing head is dirty.	Clean the erasing head.
Increased noise or poor reproduction in high frequencies.	The head is magnetized.	Demagnetize the head.
Unbalanced tone in high frequencies.	Improper setting of the DOLBY NR switch.	During playing back, set the switch to the same position used in recording.
	The unit is placed near a television set.	Move the unit away from the television set.
The desired selection cannot be located even though you activate the AMS.	There is noise in the space between selections. The space is less than four seconds long.	Rerecord the tape if you can, and insert a blank space of four seconds using the <b>O</b> button.
	The <b>▶▶</b> (or <b>◀◀</b> ) button was pressed immediately before the beginning of the following selection.	—
Playback begins in the middle of the selection when the AMS is activated.	The selection contains one of the following: — a long pause in the music — a passage of low frequencies or very low volume — a gradual increase or decrease in volume.	While the tape is playing, press the <b>▶▶</b> or <b>◀◀</b> button again.

Noise		
Symptom	Cause	Remedy
Hum noise.	The unit is stacked on or under the amplifier.	Separate the unit.
Noise is recorded.	The recording was made near equipment such as a television set or a color monitor, and interference has affected the recording on the tape and the Dolby NR system.	Move the unit away from the television set or color monitor.